

PIT JACK

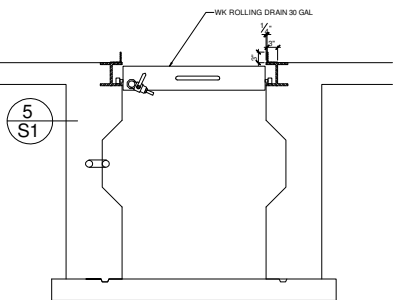

ROLLING DRAIN

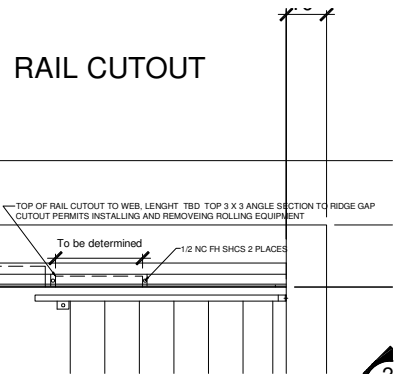

RAIL CUTOUT

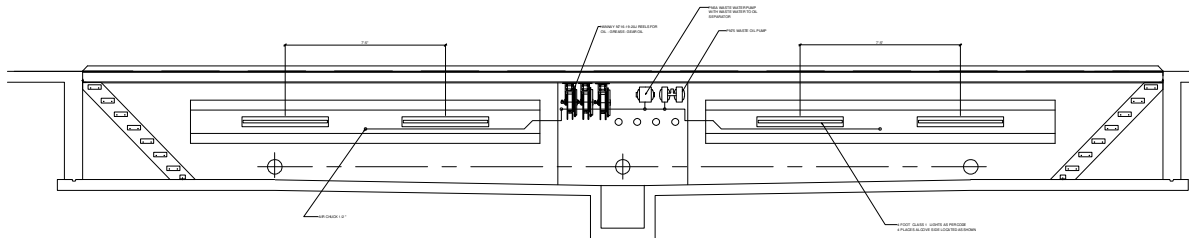

PIT ALCOVE SIDE

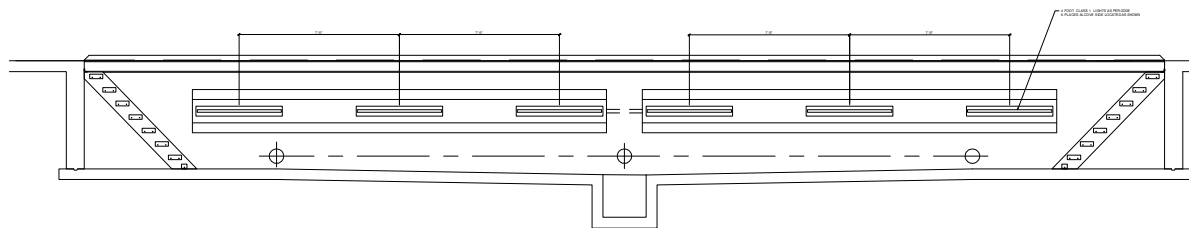

PIT SIDE OPPOSITE ALCOVE

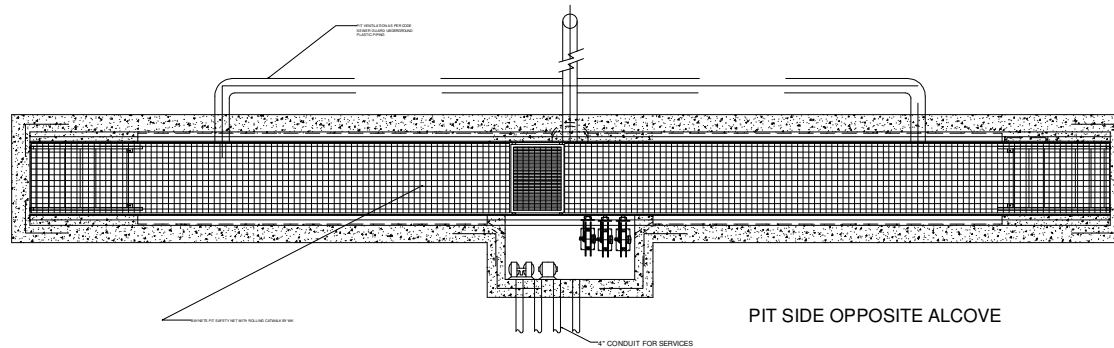

PIT SIDE OPPOSITE ALCOVE

REV	DATE	DESCRIPTION

GS
GARAGE SUPPLY CONTRACTING INC
 P.O. BOX 75 87 DUFFERIN ST
 ORILLIA, ONTARIO L3V 6H9
 PH 705-325-2771 FAX 705-330-0332

PIT EQUIPMENT
 DRAWING TITLE
**Large Vehicle Pit
 SHOP EQUIPMENT
 LAYOUT**

SCALE	DATE	REV
	25/04/10	
DRAWN	SHEET	REV
JC	1 OF 1	0