

MODEL SYSTEM I SPECIFICATIONS

- Capacity:**..... 10,000 lbs. (4535.92 kg)
- Lifting Speed:**..... 50 seconds (faster with lighter load)
- Motor Rating:**..... 2.5 HP/208-230V, Single-phase (3Ø optional)
- Synchronization:**..... Hydraulic fluid displacement using no chains, cables, or overhead obstructions
- Arm Pad Height:**..... 3½" (8.89 cm) min.
- Lifting Height:**..... 6' (1.83 m) under arm
- Arm Pad Height @ Full Rise:**..... 6' 3½" (1.84 m) min.
- Lift Pad Height with Adaptors:**..... 7' ½" (2.15 m)
- Overall Width:**..... 11' 10" (3.61 m) (**adjustable**)
- Width Between Posts:**..... 10' (3.05 m) (**adjustable**)
- Width Between Lifting Arms:**..... 8' 10" (2.69 m) (**adjustable**)
- Column Height:**..... 8' 7" (2.62 m)
- Overhead Hydraulic Line Height:** ... 12' (3.51 m) Standard (**adjustable** to accommodate any height ceiling or routed in-floor)
- Weight:**..... 2500 lbs. (1088.62 kg)
- Concrete Floor Requirements:**..... 4000 psi (27579.02 kPa) mix 4½" (11.43 cm) depth
- Anchoring System: Included**..... (16) ¾"x5" (1.9x12.7 cm) bolts
- Mechanical Safety Locks:**..... **Automatic; all position** starting @ 5" (7.62 cm) off the floor
- Hydraulic Safety Systems:**..... **Automatic;** all position
- Swing Arm Restraints:**..... **Automatic** upon ascent
- Cylinders:**..... 2 (1 per column)
- Drive System:**..... #646 leaf chain routed over cylinder
- 3" Frame Adaptors (stackable):**..... 4 included as standard equipment
- 6" Frame Adaptors (stackable):**..... 4 included as standard equipment
- Steel Carriage Bearings:**..... (8) per carriage, double sealed, self-lubricating
- Floor Access Between Posts:**..... Clear and unobstructed
- Warranty:**..... **25 years structural, 10 year mechanical, plus limited lifetime cylinder seal warranty**

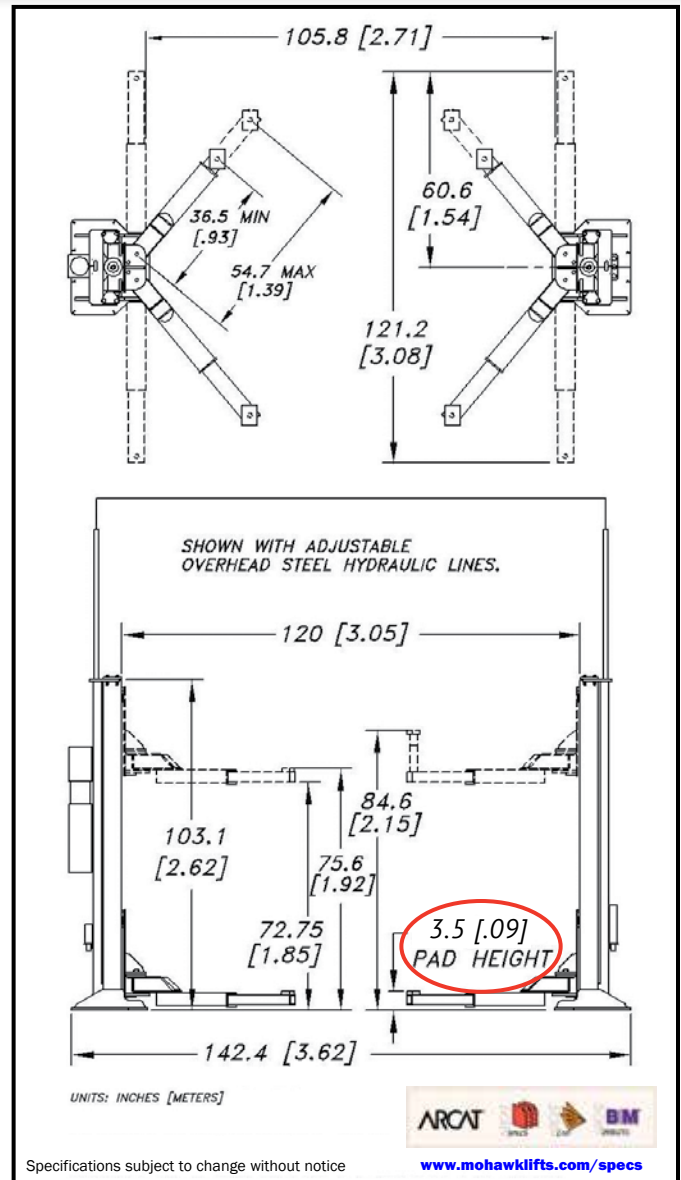

Mohawk builds the best products with the finest materials, to the highest standards. Just compare our lifts. Our staff will assist you with a fleet evaluation, design assistance and answer any technical questions you have. We invite your calls.

Mohawk lifts are manufactured in compliance with the following standards: ALI, ANSI, ASME, AISI, ASTM, ASA, NEC, AWG, NEMA.

MEETS CURRENT NATIONAL ANSI CODE FOR LIFTS.



Mohawk Resources, LTD.
P.O. Box 110
65 Vrooman Ave
Amsterdam, NY 12010
(800) 833-2006
(518) 842-1431
FAX: (518) 842-1289
www.mohawklifts.com



GSA
contract
#GS-07F-
207AA

AVAILABLE UNDER
DISCOUNTED
GOVERNMENT CONTRACT
IN ALL 50 STATES



DISTRIBUTED BY:

Scan the QR Code or Microsoft Tag to find out more about Mohawk Model System I Lift



For more detailed product information read this book at www.mohawklifts.com/wmamam

